

# 外形圖 Mechanical Dimensions

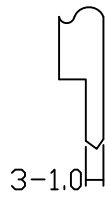

安裝孔位置圖  
Mounting Hole

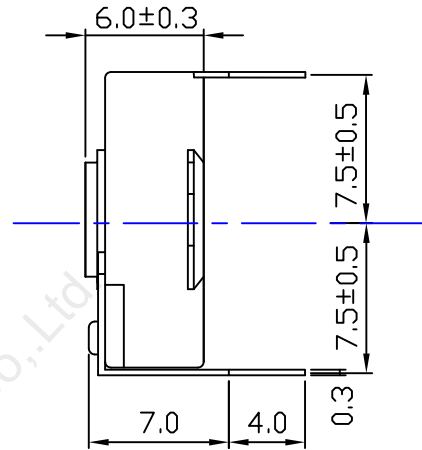
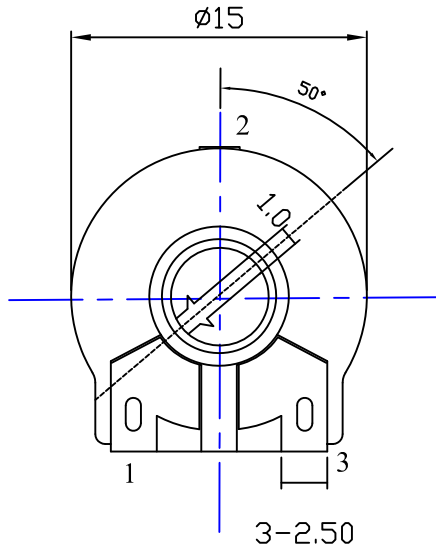
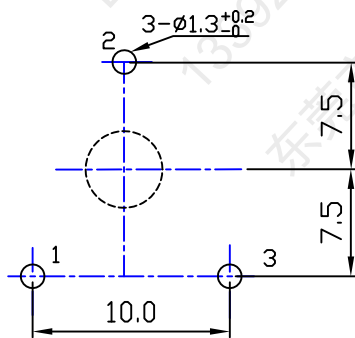

接線圖  
Circuit Explanation

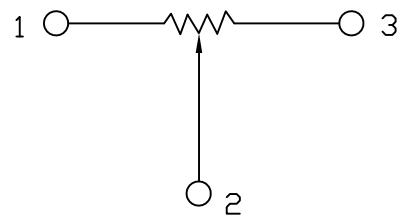

				PRODUCT NAME	15MM Spanish Potentiometers		
				MODEL NAME	SB155-1-Value		
NO	DATE	DESCRIPTION		APPROVED BY	CHECKED BY	DRAWN BY	
		DIMENSION	TOLERANCE	SCALE	2 : 1		
		$l \leq 10$	$\pm 0.2$	UNIT	mm		
		$10 < l \leq 30$	$\pm 0.5$	VER.			
		$30 < l \leq 100$	$\pm 1.0$	DATE	08/8/12		

DRAWN BY  
2011.12.30  
Lisa

# 一、微調電阻系列技術規格書

Common Specification For Semi-Fixed Potentiometers

1. 電器性能 (Electrical Characteristic)					
序号	項目			特性	
1.1	全阻抗值 (Total Resistance)			500 Ω ~ 2M Ω	
1.2	全阻抗值允許偏差 (Total Resistance Tolerance)			± 20%	
1.3	阻值變化特性 (Resistance Taper)			A, B	
1.4	零位阻值 (Residual Resistance)			Term 1~2: Less than 20 Ω Term 2~3: Less than 20 Ω	
1.5	額定功率 (Rated Power)			Carbon Film Type 0.25W	
1.6	最高使用電壓 (Max. Operating Voltage)			DC 250V	
1.7	耐電壓 (Withstand Voltage)			1 minute at DC 250V	
1.8	耐溫特性 (Temperature Characteristic)			-10°C ~ 70°C: $\Delta R/R \leq \pm 8\%$	
1.9	潮濕環境下負載性能 (Load Life In Humidity)			<u>20%</u> Max <u>350</u> hours rated in <u>90%RH</u> <u>40°C</u>	
2. 機械性能 (Mechanical Characteristics)					
2.1	全回轉角度 (Rotation Angle)			265° ± 10°	
2.2	旋轉力矩 (Rotation Torque)			10~30gf. cm	
2.3	轉動止檔強度 (Rotational Stop-End Torque)			1Kgf. cm. max	
2.4	焊錫耐熱性 (Resistance to soldering heat)			<u>260 ± 5°C</u> and less than <u>3</u> seconds	
3. 耐久性能 (Durability)					
3.1	回轉壽命 (Rotation Life)			10,000 cycles min	
4. 外形尺寸圖/曲線特性圖 (Shape size drawing/curve characteristic drawing)				見附頁 (Please see attachment)	
批 准		審 核		設 計	



東莞市雅弧電子有限公司  
DongGuan YaHu Electronic Co.,Ltd.

# RESISTANCE TAPER

### TAPER B SERIES

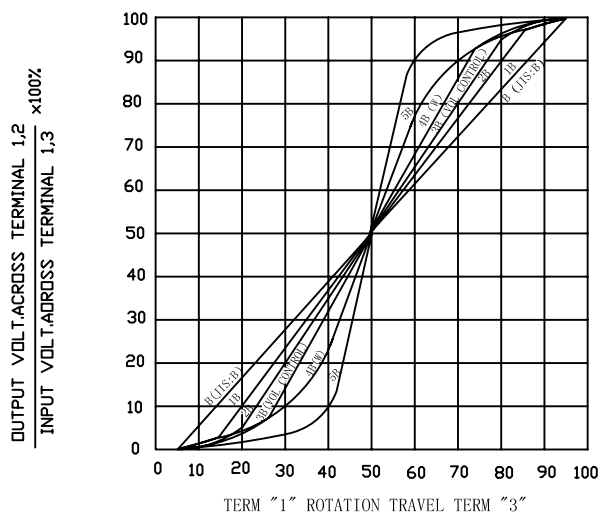

### TAPER B WITH 50% TAP

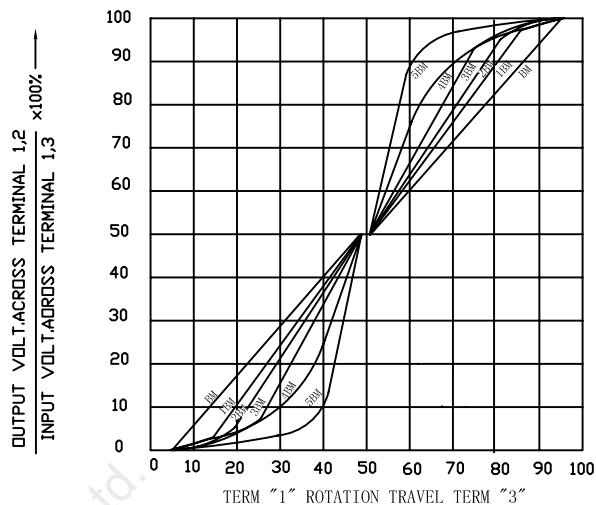

### TAPER A SERIES

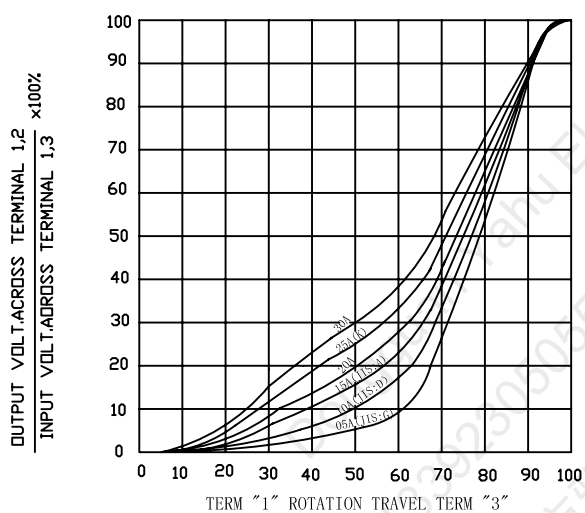

### TAPER A & C WITH 50% TAP

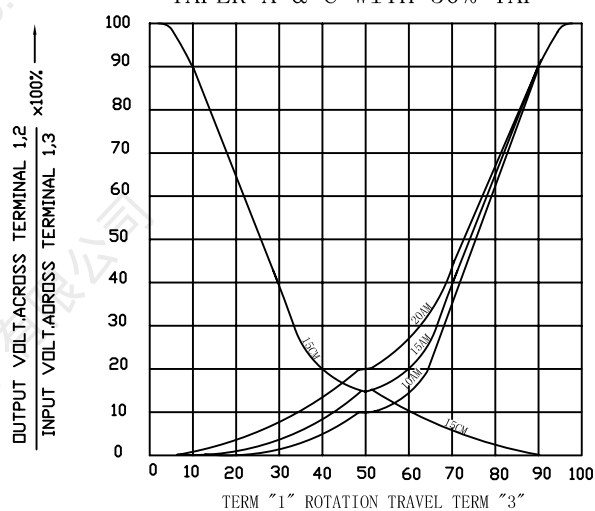

### TAPER C SERIES

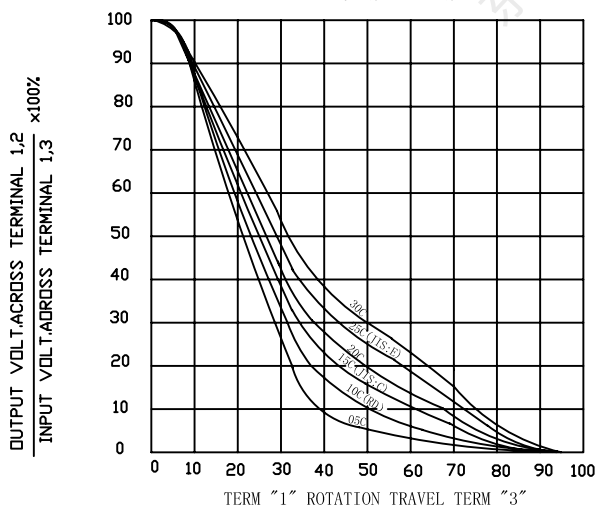

### TAPER M & N SERIES

